

FIX-A-TAP®

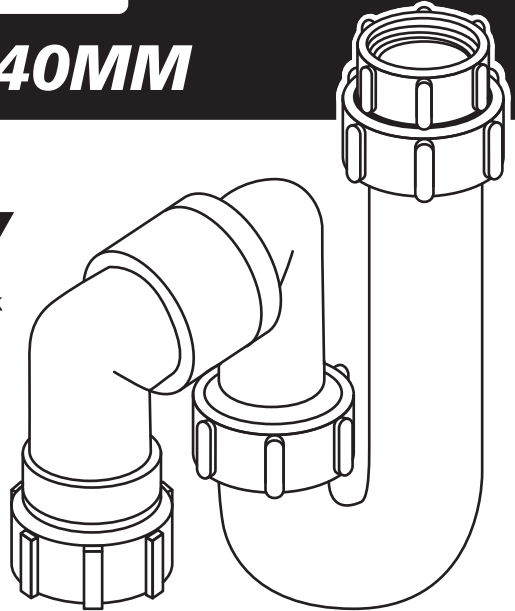

S & P TRAP 32/40MM

Assemble as per diagram.
Product to be installed by a
licensed plumber in
accordance with local, state
and national building codes
and regulatory standards.



ASSEMBLY INSTRUCTIONS

Insert washer
to sit flat in
adaptor

Stretch square
edged washers
over pipe to sit
flat on the
shoulders

For 32mm connections, screw nut
over thread and hand tighten

Insert the tapered
washer into the
chamfered end for
40mm waste pipes.

Screw nuts
over thread
and hand
tighten



For more
information
on recycling
visit ar1.org.au



A family owned
Australian business

Quality Assured Products
FIX-A-TAP has been providing
Australians with quality
plumbing products since 1972.



FIX-A-TAP®
AUSTRALIA PTY LTD
The Ultimate Plumbing Solution
PO Box 200 Wahroonga
NSW Australia 2076
www.fixatap.com.au
Made in China

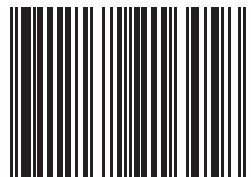

9 312232 216458 >